

Full lift safety valve with spring loading. (AIT)

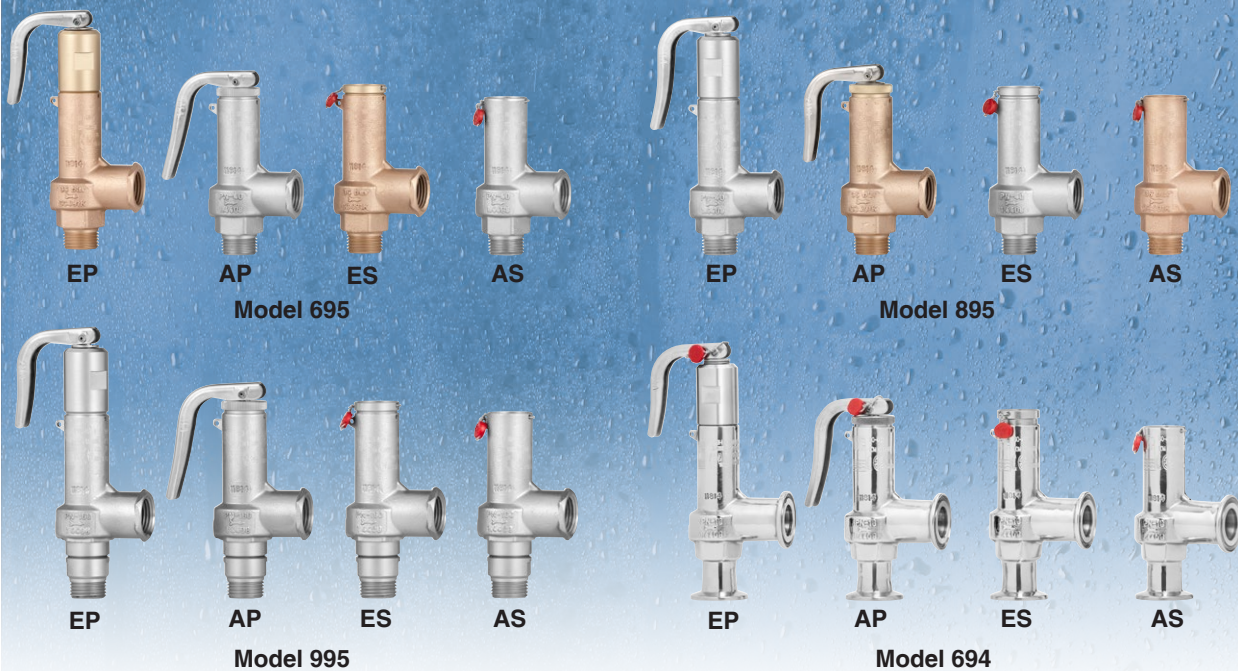

EN

Model 695 Model 895 Model 995 Model 694



The valve works as an automatic pressure releasing regulator activated by the static pressure existing at the entrance to the valve and is characterized by its ability to open instantly and totally.

Design in accordance with "International Standard ISO 4126-1 Safety Valves".

In accordance with the requirements of the pressure equipment directive 2014/68/EU.

EC valve verification certified by: TÜV Internacional Grupo TÜV Rheinland, S.L. EC 0035.

Type (Module D) EC examination report nº 33530455 certified by: TÜV Internacional Grupo TÜV Rheinland, S.L.

In compliance with the ATEX 2014/34/EU directive "Protective equipment and systems for use in potentially explosive atmospheres".

Other authorisations: IS CIR, ITI, NASTHOL, EAC, ... etc.

Specifications

- 90° angular flow.
- Activated by direct action helicoid spring.
- Simplicity of construction ensuring minimum maintenance.
- Materials carefully selected for their resistance to corrosion.
- Internal body designed to offer favourable flow profile.
- Sealing surfaces balanced and making them extremely tightness, even exceeding EN 12266-1 requirements.
- Great discharge capacity. For liquids typically used with openings similar to proportional safety valves.
- Auto-centering plug.
- Totally precise open and close.
- All the valves are supplied sealed at the set pressure requested, simulating operational conditions, and are vigorously tested.
- All components are numbered, registered and checked. If requested in advance, material, casting, test and efficiency certificates will be enclosed with the valve, and the instruction manual, in accordance with P.E.D. 2014/68/EU.

IMPORTANT

1.- Fluorelastomer (Vitón) seals, Silicone's rubber, PTFE (Teflón) o Perfluorelastomer (FFKM).

Achieving leakage levels less than: $0,3 \times 10^{-3} \frac{\text{Pa cm}^3}{\text{seg.}}$

		RANGE OF APPLICATION FOR THE SEALS							
		SET PRESSURE IN bar							
FLUID		0,20	1,80	4,80	20,00	30,00	36,01	45,00	144,00
Saturated steam		S		V		K		T	
Liquids and gases		S			V		K		T
SEALS		TEMPERATURE IN °C							
		MINIMUM			MAXIMUM				
Silicone's rubber	S	-50			200				
Fluorelastomer (Vitón)	V	-20			220				
PTFE (Teflón)	T	-196			260				
Perfluorelastomer (FFKM)	K	-10			250				

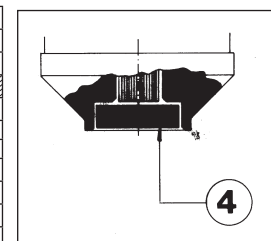

Depending on demand:

1. Buna-nitrils seals, Butyl, Natural rubber, E.P.D.M., Chlorosulphonate polyethylene (Hypalon), Neoprene, etc.
2. Possibility of manufacture in other types of material, for use in special working conditions (high temperatures, fluids, etc.).

N.º PIECE	PIECE	MATERIAL	
		BRONZE	STAINLESS STEEL
1	Body	Bronze (EN-CC491K)	S. steel (EN-1.4408)
2	Plug	Brass (EN-CW617N)	S. steel (EN-1.4401)
3	Shaft	S. steel (EN-1.4305)	S. steel (EN-1.4305)
4	Seal	Silicone's rubber	Silicone's rubber
		Fluorelastomer (Viton)	Fluorelastomer (Viton)
		PTFE (Teflon)	PTFE (Teflon)
		Perfluorelastomer (FFKM)	Perfluorelastómero (FFKM)
5	Limiter ring	S. steel (EN-1.4310)	S. steel (EN-1.4310)
6	End-stop	PTFE (Teflon)	PTFE (Teflon)
7	Spring press	Brass (EN-CW617N)	S. steel (EN-1.4305)
8	Spring	S. steel (EN-1.4310)	S. steel (EN-1.4310)
9	Clip	S. steel (EN-1.4310)	S. steel (EN-1.4310)
10	Lever	S. steel (EN-1.4301)	S. steel (EN-1.4301)
11	Sealing wire	Sealing wire	Sealing wire
12	Characteristic plate	Aluminium	Aluminium
13	Seal	Plastic	Plastic
14	Cap	Brass (EN-CW617N)	S. steel (EN-1.4305)
15	Hood coupling	PTFE (Teflón)	PTFE (Teflón)
16	Piston	Latón (EN-CW617N)	S. steel (EN-1.4305)
17	Piston Spring	S. steel (EN-1.4310)	S. steel (EN-1.4310)
18	Inlet clamp	-	S. steel (EN-1.4404)
19	Outlet clamp	-	S. steel (EN-1.4404)
20	O-ring	Fluorelastomer (Viton) (1)	Fluorelastomer (Viton) (1)
21	Seat	-	S. steel (EN-1.4401)
22	Screw cap	S. steel (EN-1.4305)	S. steel (EN-1.4305)

MODEL		R ₁ xR ₂	3/8"x1/2" to 1"x1"	
			PN	PMS 36 bar
695	OPERATING CONDITIONS	PN	PMS 36 bar	40
		PRESSURE IN bar	36	36
		MAX. TEMPERATURE IN °C	200	250
		MIN. TEMPERATURE IN °C	-60	-60
895	OPERATING CONDITIONS	PN	PMS 36 bar	40
		PRESSURE IN bar	36	36
		MAX. TEMPERATURE IN °C	60	60
		MIN. TEMPERATURE IN °C	-196	-196
995	OPERATING CONDITIONS	PN		160
		PRESSURE IN bar	-	144
		MAX. TEMPERATURE IN °C	-	250
		MIN. TEMPERATURE IN °C	-	-60
694	OPERATING CONDITIONS	PN		16
		PRESSURE IN bar	-	16
		MAX. TEMPERATURE IN °C	-	250
		MIN. TEMPERATURE IN °C	-	-60

(1) Mod. 895; Perfluorelastomer (FFKM)

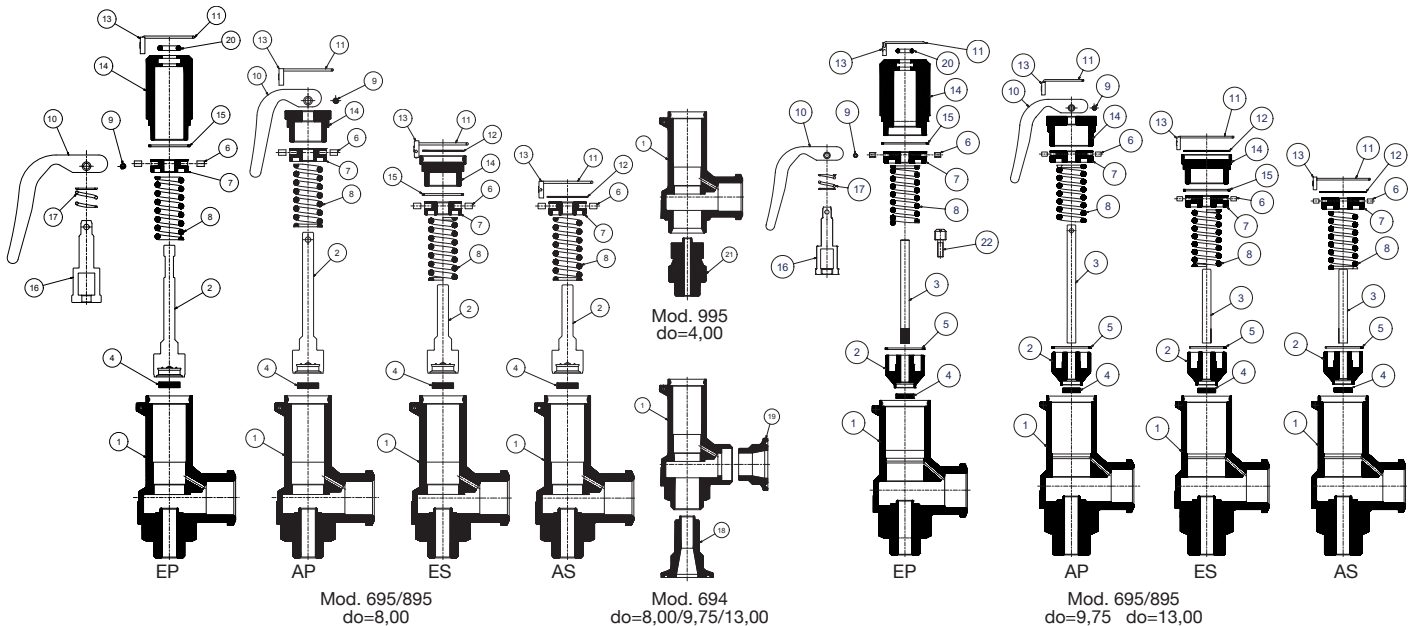

Full lift safety valve with spring loading (AIT) version EP.

1. Disassembly and assembly

1.1 Disassembly

To replace the spring (8) or clean any of the internal components of the valve, proceed in the following manner:

- A - Cut the seal thread (11) with pliers.
- B - Withdraw the fastener (9), using a punching tool, until the lever (10) comes free.
- C - Unscrew and extract the hood (14).
- D - Unscrew the piston (16) from the rod (3) and then the screw cap (22).
- E - Holding the rod (3), unscrew the spring press (7) until you note a releasing of the spring (8).
- F - Extract the spring (8).

1.2 Assembly

- A - Enter the spring (8) through the upper part of the rod (3).
- B - Screw the spring press (7) holding the rod (3) and the screw cap (22).
- C - Adjust the set pressure with the spring press (7).
- D - Screw the piston (16) to the rod (3).
- E - Screw the hood (14).
- F - Place the lever (10) and fix it with the fastener (9).

2. Adjusting the firing pressure

- A - Proceed according to points 1.1.A, 1.1.B, 1.1.C, 1.1.D, 1.1.E.
- B - Proceed according to points 1.2.C, 1.2.D, 1.1.E, 1.1.F.

Full lift safety valve with spring loading (AIT) version AP.

1. Disassembly and assembly

1.1 Disassembly

To replace the spring (8) or clean any of the internal components of the valve, proceed in the following manner:

- A - Cut the seal thread (11) with pliers.
- B - Withdraw the clip (9), using a punching tool, until the lever (10) comes free.
- C - Unscrew and extract the hood (14).
- D - Holding the rod (3), unscrew the spring press (7) until you note a releasing of the spring (8).
- E - Extract the spring (8).

1.2 Assembly

- A - Enter the spring (8) through the upper part of the rod (3).
- B - Screw the spring press (7) holding the rod (3).
- C - Adjust the set pressure with the spring press (7).
- D - Screw the hood (14).
- E - Place the lever (10) and fix it with the fastener (9).

2. Adjusting the firing pressure

- A - Proceed according to points 1.1.A, 1.1.B, 1.1.C, 1.1.D.
- B - Proceed according to points 1.2.C, 1.2.D, 1.1.E.

Full lift safety valve with spring loading (AIT) version ES.

1. Disassembly and assembly

1.1 Disassembly

To replace the spring (8) or clean any of the internal components of the valve, proceed in the following manner:

- A - Cut the seal thread (11) with pliers and extract the characteristic plate (12).
- B - Unscrew and extract the hood (14).
- C - Holding the rod (3), unscrew the spring press (7) until you note a releasing of the spring (8).
- D - Extract the spring (8).

1.2 Assembly

- A - Enter the spring (8) through the upper part of the rod (3).
- B - Screw the spring press (7) holding the rod (3).
- C - Adjust the set pressure with the spring press (7).
- D - Screw the hood (14).

2. Adjusting the firing pressure

- A - Proceed according to points 1.1.A, 1.1.B, 1.1.C.
- B - Proceed according to points 1.2.C, 1.2.D..

Full lift safety valve with spring loading (AIT) version AS.

1. Disassembly and assembly

1.1 Disassembly

To replace the spring (8) or clean any of the internal components of the valve, proceed in the following manner:

- A - Cut the seal thread (11) with pliers and extract the characteristic plate (12).
- B - Holding the rod (3), unscrew the spring press (7) until you note a releasing of the spring (8).
- C - Extract the spring (8).

1.2 Assembly

- A - Enter the spring (8) through the upper part of the rod (3).
- B - Screw the spring press (7) holding the rod (3).
- C - Adjust the set pressure with the spring press (7).

2. Adjusting the firing pressure

- A - Proceed according to points 1.1.A, 1.1.B.
- B - Proceed according to points 1.2.C.

MODEL 695/895/995												
R ₁ xR ₂		3/8"x1/2"				1/2"x 1/2"				1/2"x 3/4"		
CONNECTIONS		Male thread x Female thread Whitworth gas-tight cylindrical ISO 228/1										
MODEL 694												
DN ₁ xDN ₂		10x15				15x15				15x20		
CONNECTIONS		CLAMP ISO 2852:1993										
d ₀	694/695/895	8,00								9,75		
	995	4,00										
$A_0 = \frac{\pi \cdot d_0^2}{4}$	694/695/895	50,26								74,66		
	995	12,57										
H	695/895	-	-	-	88	-	-	-	91	-	-	
	995	-	-	-	99	-	-	-	102	-	-	
	694	-	-	-	101	-	-	-	101	-	-	
H ¹	695/895	136	102	93	-	139	105	96	-	164	127	
	995	147	113	104	-	150	116	107	-	-	-	
	694	149	115	106	-	149	115	106	-	176	139	
h ¹	695/895	148	119	109	-	151	122	112	-	178	142	
	995	159	130	120	-	162	133	123	-	-	-	
	694	161	132	122	-	161	132	122	-	190	154	
A	695/895/995	9				12				12		
	694					22				24		
L ₁	695/895/995					36				44		
	694					41,50				52		
L ₂	695/895	32,50				35,50				45,50		
	995	43,50				46,50						
	694					45,50				57,50		
INTAKE FLANGE	PN-16 CLAMP ISO 2852:1993	C ₆₁				14				18,10		
		C ₇₁				34				34		
		C ₂₁				27,50				27,50		
		L ₁₁				2,85				2,85		
ESCAPE FLANGE	PN-16 CLAMP ISO 2852:1993	C ₆₂				18,10				23,70		
		C ₇₂				34				50,50		
		C ₂₂				27,50				43,50		
		L ₁₂				2,85				2,85		
WEIGHT IN Kgs.		EP	AP	ES	AS	EP	AP	ES	AS	EP	AP	
695/895/995	BRONZE	0,47	0,38	0,36	0,34	0,47	0,38	0,36	0,34	0,97	0,74	
	S. STEEL	0,45	0,36	0,34	0,32	0,45	0,36	0,34	0,32	0,95	0,72	
694	S. STEEL	0,50	0,41	0,39	0,37	0,50	0,41	0,39	0,37	1,06	0,83	
CODE	695	BRONZE 2002-695.	83810	838110	838120	838130	80210	802110	802120	802130	80211	802111
		S. STEEL 2002-695.	83820	838210	838220	838230	80220	802210	802220	802230	80221	802211
	895	BRONZE 2002-895.	83810	838110	838120	838130	80210	802110	802120	802130	80211	802111
		S. STEEL 2002-895.	83820	838210	838220	838230	80220	802210	802220	802230	80221	802211
	995	S. STEEL 2002-995.	03820	03821	03822	03823	0022	00221	00222	00223		
		S. STEEL 2002-694.	83820	838210	838220	838230	80220	802210	802220	802230	80221	802211

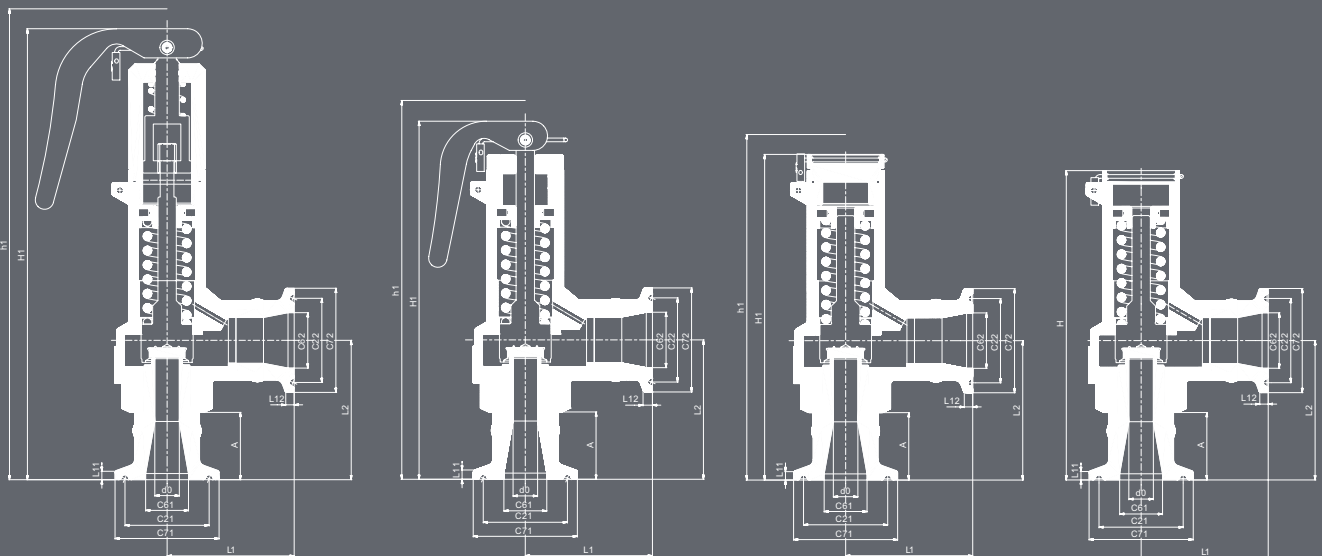

MODEL 695/895/995

1/2"x 3/4"

3/4"x3/4"

3/4"x1"

1"x1"

Male thread x Female thread Whitworth gas-tight cylindrical ISO 228/1

MODEL 694

15x20

20x20

20x25

25x25

CLAMP ISO 2852:1993

9,75

13,00

74,66

132,73

- 109 - - - 112 - - - 138 - - - 141

- 121 - - - 121 - - - 148 - - - 148

116 - 167 130 119 - 196 159 147 - 199 162 150 -

128 - 176 139 128 - 206 169 157 - 206 169 157 -

134 - 181 145 137 - 210 174 165 - 213 147 168 -

146 - 190 154 146 - 220 184 175 - 220 154 175 -

12

15

15

18

24

25

44

60

52

67

45,50

48,50

58,50

61,50

57,50

68,5

18,10

23,70

23,70

29,70

34

50,50

50,50

27,50

43,50

43,50

2,85

2,85

23,70

29,70

50,50

50,50

43,50

43,50

2,85

2,85

ES

AS

EP

AP

ES

AS

EP

AP

ES

AS

EP

AP

ES

AS

0,72

0,70

0,97

0,74

0,72

0,70

1,67

1,35

1,33

1,31

1,67

1,35

1,33

1,31

0,70

0,68

0,95

0,72

0,70

0,68

1,65

1,33

1,31

1,29

1,65

1,33

1,31

1,29

0,81

0,79

1,10

0,87

0,85

0,83

1,74

1,52

1,50

1,48

1,02

1,80

1,78

1,76

802121

802131

83410

834110

834120

834130

83411

834111

834121

834131

81010

810110

810120

810130

802221

802231

83420

834210

834220

834230

83421

834211

834221

834231

81020

810210

810220

810230

802121

002131

83410

834110

834120

834130

83411

834111

834121

834131

81010

810110

810120

810130

802221

802231

83420

834210

834220

834230

83421

834211

834221

834231

81020

810210

810220

810230

802221

802231

83420

834210

834220

834230

83421

834211

834221

834231

81020

810210

810220

810230

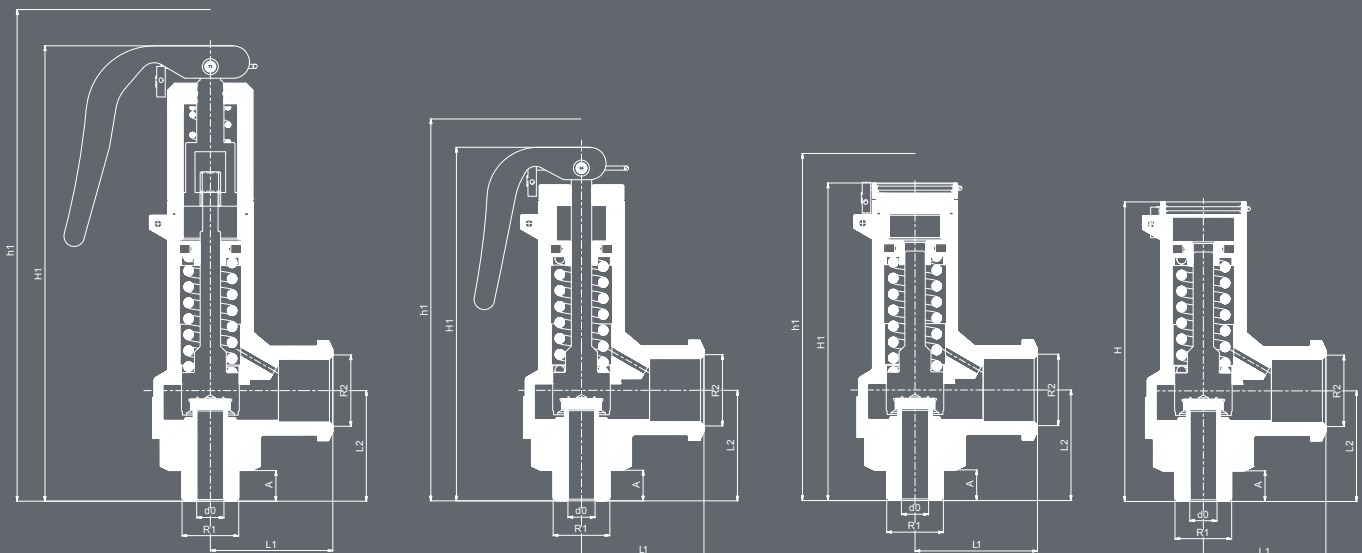

SET PRESSURES AND REGULATING RANGES									
MODEL			695/895/995/694						
ENTRY CONNECTION	695/895/995		R ₁	3/8"	1/2"	1/2"	3/4"	3/4"	1"
	694		DN ₁	10	15	15	20	20	25
EXIT CONNECTION	695/895/995		R ₂	1/2"		3/4"		1"	
	694		DN ₂	15		20		25	
d ₀	695/895/694			8,00		9,75		13,00	
	995			4,00					
SET PRESSURE IN bar	MAXIMUM	695/895	PMS. 36 bar	36		36		36	
		695	PN-40	36		36		36	
		995	PN-160	144					
		694	PN-16	16		16		16	
	MINIMUM	695/895	PMS. 36 bar	0,2		0,2		0,2	
		695	PN-40	0,2		0,2		0,2	
		995	PN-160	36,1					
		694	PN-16	0,2		0,2		0,2	
SPRING REGULATING RANGE IN bar	695/895/694	995							
	0,20 to 0,70		CODE	56160		56169		56178	
	0,60 to 1,60		CODE	56161		56170		56179	
	1,50 to 3,50		CODE	56162		56171		56180	
	3,40 to 5,50		CODE	56163		56172		56181	
	5,40 to 10,00	36,10 to 40,00	CODE	56164- 56334		56173		56182	
	9,80 to 15,00	39,00 to 60,00	CODE	56165- 56335		56174		56183	
	14,50 to 20,00	58,00 to 80,00	CODE	56166- 56336		56175		56184	
	19,00 to 25,00	76,00 to 100,00	CODE	56167- 56337		56176		56185	
	24,00 to 36,00	96,00 to 144,00	CODE	56168- 56338		56177		56186	

RECOMMENDED RANGES OF APPLICATION							
MODEL			695/895/995/694				
			AP	AS	EP	ES	
FLUID	SATURATED STEAM			*	*	*	*
	GASES	INERT		*	*	*	*
		NON INERT				*	*
	LIQUIDS					*	*
OPENING PRESSURE IN % OF THE SET PRESSURE			+10%				
CLOSURE PRESSURE IN % OF THE SET PRESSURE			-10%				

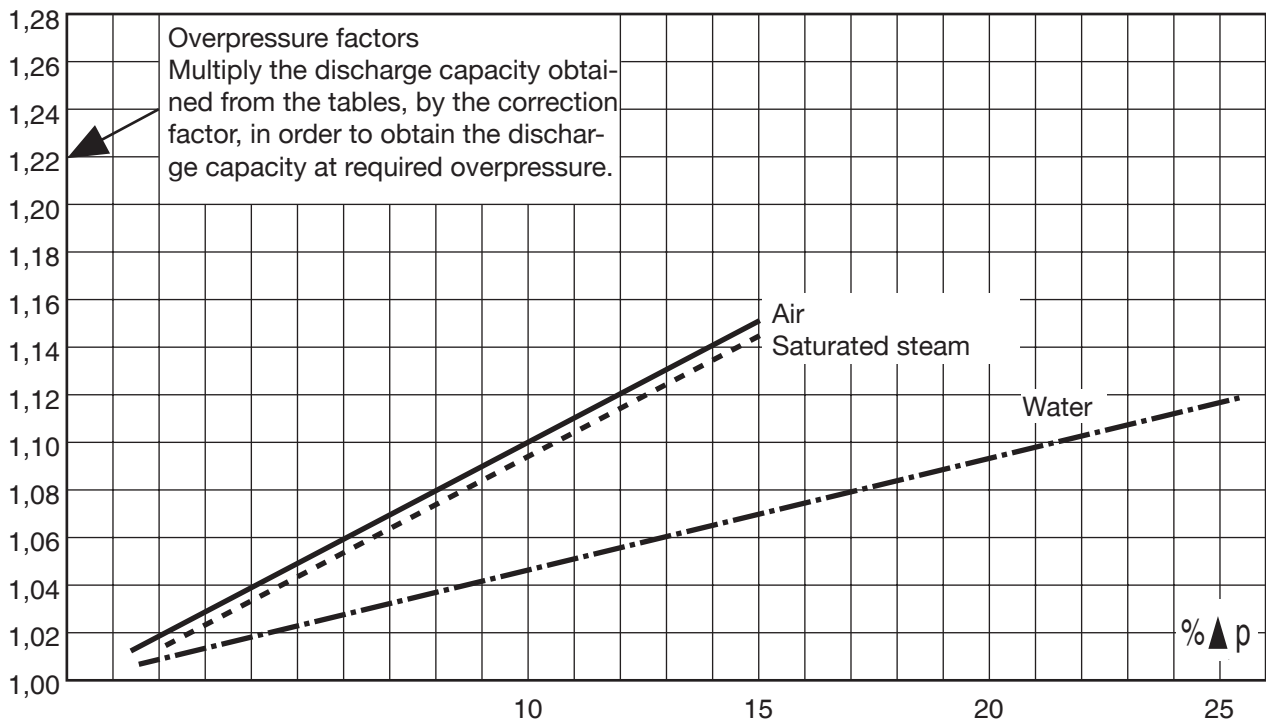
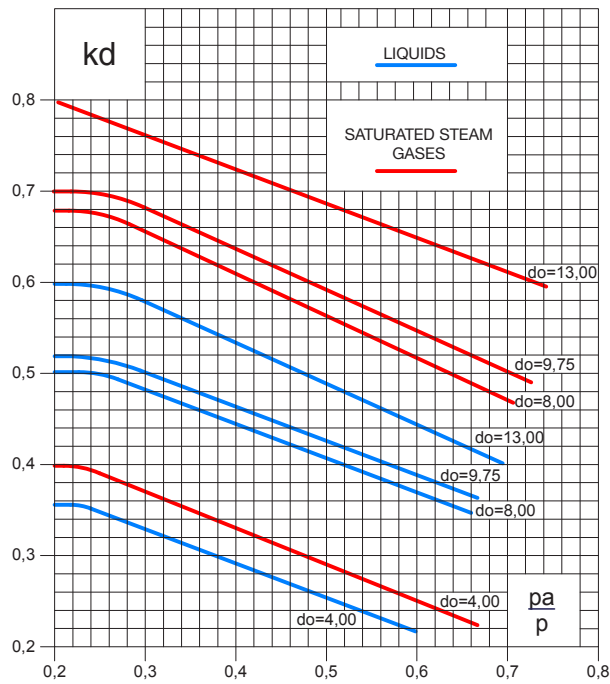

DISCHARGE CAPACITY												
MODEL	695-895									995		
ENTRY CONNECTION	R1	3/8"	1/2"	1/2"	3/4"	3/4"	1"	3/8"	1/2"			
EXIT CONNECTION	R2	1/2"		3/4"		1"			1/2"			
MODEL	694											
ENTRY CONNECTION	DN1	10	15	15	20	20	25					
EXIT CONNECTION	DN2	15		20		25						
do		8,00		9,75		13,00			4,00			
$A_0 = \frac{\pi \cdot d_0^2}{4}$		50,26		74,66		132,73			12,57			
p [bar]	For other, not so dense liquids, other than water at 20°C apply:											
SET PRESSURE IN bar	$V_i = \sqrt{\frac{\rho A}{\rho L}} \cdot V_A \quad V_i = V_i \cdot \sqrt{\frac{\rho A}{\rho L}}$ <p> I- Saturated steam in kg/h. II- Air at 0°C and 1.013 bar in [Nm³/h]. III- Water at 20°C in l/h. </p> <p> V_i = Water flow according to table. V_i = Liquid flow. ρA = Water density at a 20° C. (ρA= 998 kg/m³) ρL = Liquid density. </p>											
	I	II	III	I	II	III	I	II	III	I	II	III
0,5	30	34	924	45	51	1399	91	103	2870			
1,0	39	47	1306	59	71	1979	120	144	4059			
1,5	49	59	1600	73	88	2423	149	180	4971			
2,0	58	70	1848	87	106	2798	178	215	5740			
2,5	67	82	2066	101	124	3128	206	251	6417			
3,0	77	94	2263	115	141	3427	235	287	7030			
3,5	86	105	2444	129	159	3702	263	323	7593			
4,0	95	117	2613	143	176	3957	291	359	8117			
4,5	104	129	2771	157	194	4197	320	395	8610			
5,0	113	140	2921	171	212	4424	348	431	9076			
6,0	132	164	3200	198	247	4847	404	503	9942			
7,0	150	187	3457	226	282	5235	460	575	10738			
8,0	168	211	3695	253	318	5596	515	646	11480			
9,0	186	234	3919	281	353	5936	571	718	12176			
10,0	204	258	4131	308	388	6257	627	790	12835			
12,0	240	304	4526	362	459	6854	738	934	14060			
14,0	277	351	4888	417	529	7403	849	1077	15186			
16,0	313	398	5226	471	600	7915	960	1221	16235			
18,0	349	445	5543	526	670	8395	1070	1365	17220			
20,0	385	492	5843	580	741	8849	1182	1508	18151			
22,0	421	538	6128	635	812	9281	1293	1652	19037			
24,0	458	585	6400	690	882	9693	1404	1796	19884			
26,0	494	632	6662	745	953	10089	1516	1939	20696			
28,0	531	679	6913	800	1023	10470	1628	2083	21477			
30,0	567	726	7156	855	1094	10837	1740	2226	22231			
32,0	604	773	7391	910	1164	11193	1852	2370	22960			
34,0	641	819	7618	966	1235	11537	1965	2514	23666			
36,0	678	866	7839	1021	1306	11872	2079	2657	24352			
38,0										102	134	1363
40,0										105	141	1382
42,0										107	148	1400
44,0										110	155	1418
46,0										112	162	1435
48,0											169	1453
50,0											176	1470
52,0											182	1487
54,0											189	1504
56,0											196	1520
58,0											203	1537
60,0											210	1553
62,0											217	1569
64,0											224	1585
66,0											231	1601
68,0											238	1616
70,0											244	1632
72,0											251	1647
74,0											258	1662
76,0											265	1677
78,0											272	1692
80,0											279	1707
82,0											286	1722
84,0											293	1736
86,0											300	1751
88,0											306	1765
90,0											313	1779
92,0											320	1793
94,0											327	1807
96,0											334	1821
98,0											341	1835
100,0											348	1848
105,0											365	1902
110,0											382	1954
115,0											399	2005
120,0											417	2054
125,0											434	2103
130,0											451	2150
135,0											468	2196
140,0											485	2242
145,0											503	2286

COEFFICIENT OF DISCHARGE										
MODEL										
695/895/995/694										
ENTRY CONNECTION	695/895/995	R ₁	3/8"	1/2"	1/2"	3/4"	3/4"	1"		
	694	DN ₁	10	15	15	20	20	25		
EXIT CONNECTION	695/895/995	R ₂	1/2"		3/4"		1"			
	694	DN ₂	15		20		25			
d ₀	695/895/694		8,00		9,75		13,00			
	995		4,00							
h	695/895/694		2,50		4,00		5,50			
	995		0,31		0,41		0,42			
h/d ₀	695/895/694		0,68		0,69		0,79			
	995		0,40							
COEFFICIENT OF DISCHARGE kd (1)	695/895/694		0,51		0,52		0,60			
	995		0,35							

(1) For set pressures less than 3 bar see graph of discharge coefficient.

pa = Backpressure permitted [bar] absolute.
p = Set pressure [bar] absolute.
kd = Coefficient of discharge.

Calculus according to ISO 4126-1 "Safety valves".